

A Hybrid Energy Storage Device with Battery and Supercapacitor

*Muhammad Ibrahim¹, Dr. Ali Asghar Memon²

Department of Electrical Engineering, Mehran University of Engineering and Technology, Jamshoro, Pakistan

Corresponding author e-mail: (ibrahim_jatoi101@yahoo.com)

[Received on: 15/09/2023 Accepted on: 16/11/2023 Published on: 01/12/2023]

Abstract-In DC electrical power supply systems, frequent power fluctuations often result in continuous power variations, leading to system harmonics. The harmonics in traditional batteries degrade it before reaching their anticipated lifespan. This challenge is effectively tackled by hybrid energy storage devices that proficiently manage power absorption from fluctuating sources, consequently safeguarding battery longevity while enhancing overall performance. The proposed hybrid solution combines supercapacitor bank and battery to address this concern comprehensively. This innovative device excels in rapidly responding to power fluctuations, skillfully handling tasks like inrush current absorption. This abstract introduces an experimental setup designed to explore the power constraint and advantage inherent in the supercapacitor-and-battery-hybrid-device, experimental setup undergoes testing under charging. The experimental results show that supercapacitor absorbs inrush current due to high power density and battery absorbs high energy due to high energy density.

Keywords: Power Quality, Renewable Energy, Storage Devices, Power Storage Device.

I. INTRODUCTION

In recent days, the demand for reliable power storage has surged as the world shifts towards more efficient and sustainable energy production. Solar and wind power stations, while producing energy, face unpredictability due to environmental conditions, necessitating dependable energy storage devices. Traditional batteries, while convenient, have limitations, with rapid charging and discharging negatively impacting their lifespan. To overcome instant charging surge, hybrid energy storage devices combining supercapacitors and battery have emerged as promising solution. The combination of supercapacitors' fast-charging capabilities and batteries' high energy density offers efficient power storage, ensuring both instant and continuous power absorb without lag. This introduction highlights the need for innovative energy storage solutions and the advantages of adopting hybrid devices to enhance power grid stability and reliability. Cutting-edge Battery-ultracapacitor hybrids (BUHs), balancing high energy/power capacities and prolonged cycling durability, find wide-ranging uses; this survey explores their principles, materials, flexibility, and future pathways, encompassing innovative aqueous and 3D configurations [1]. Using MATLAB/Simulink, a direct parallel connection was

simulated between a high-energy Li-ion battery (MP 176065 Integration) and an ultracapacitor (BCAP0310 P250), yielding varied energy ratios, and Ragone plots illustrated improved hybrid performance in constant power and pulsed discharges, extending into inaccessible energy-power regions, contingent on pulse pattern and relative energy distribution [2]. In a Matlab/Simulink model of a stand-alone photovoltaic system, maintaining an uninterrupted energy supply during periods of low solar irradiation often necessitates energy storage; combining Valve Regulated Lead Acid (VRLA) batteries with supercapacitors creates a hybrid solution to handle high power demands and optimize power flow, resulting in increased specific power compared to standalone battery storage [3]. Study presents level-2 controller for hybrid energy storage (HESS) with lead-acid batteries and supercapacitors, optimizing via scheduling and real-time control, demonstrated with a 6.6 MW PV plant case and lab-scale prototype, enabling efficient renewable energy integration for distribution systems [4]. MEV optimized supercapacitor/battery HESS using custom parameterization, fuzzy control, and dynamic simulation, highlighting superior dynamics and economy via established LCC model, with future potential as related technologies advance [5].

Previous studies have revealed that batteries tend to lag in terms of high power density, while supercapacitors lag in achieving high energy density. These findings have been theoretically and empirically validated in the aforementioned research. Addressing this dilemma, the proposed solution involves the integration of supercapacitors and batteries in a hybrid energy storage device. Here, high energy density refers to the capacity for storing/supplying a greater amount of energy by the device, whereas high power density signifies the speed at which the device can be charged and discharged.

Notably, the experimental setup discussed in this research has not been explored in prior studies. Therefore, this study focuses on investigating the prototype experimental setup of a hybrid energy storage device, specifically to see the interplay between supercapacitors and batteries during the charging process.

II. RESULTS FROM THE EXPERIMENTAL SETUP

The experimental setup is created after selecting the proper devices, including supercapacitors, battery, a power source, and loads. The selected devices are arranged in a specific order to facilitate the experiment. First, a suitable supercapacitor bank is created (discussed in Section A.) to match the battery parameters, ensuring no damage occur to either component. Next, the supercapacitor bank is paralleled with the battery, for creating a hybrid energy storage device (discussed in Section C.). This configuration allows efficient utilization of both components' strengths. Lastly, the hybrid device undergoes analysis, and the data is presented using graphs for easy understanding. This experimental approach aims to provide valuable insights into the hybrid device's performance and behavior, contributing to advancements in sustainable and efficient energy storage solution and absorbs inrush current while charging.

A. Supercapacitor Bank

Supercapacitors are series and parallel to create a supercapacitor-bank. The developed block diagram and circuit diagram of the physically created supercapacitor bank for experimentation purpose is illustrated in Figure 1(a) and Figure 1(b). Based on experimental findings, its rating is determined to be a 14.4V, 333.33F supercapacitor bank. The next step involves paralleling it with the battery. However, it is essential to exercise caution during this experimentation process. If the supercapacitor bank is under voltage when being paralleled to battery, there is a risk of damaging or degrading the supercapacitor/s by the battery. Careful attention must be paid while designing the supercapacitor bank to prevent such undesirable outcomes.

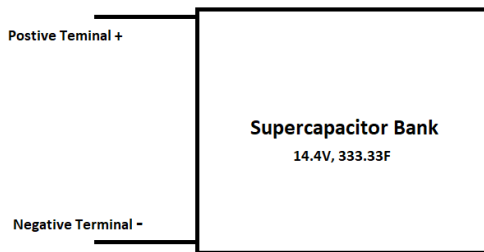
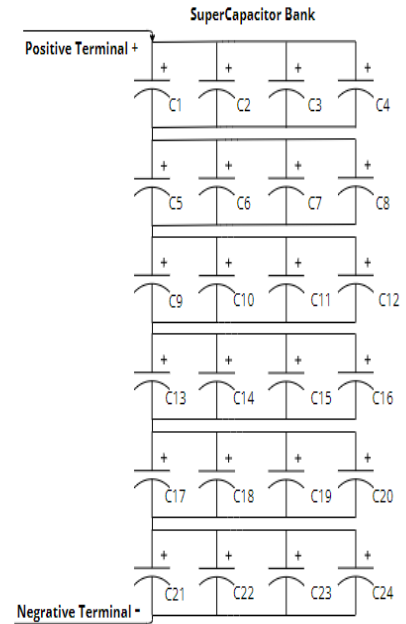

Figure 1(a). 14.4V and 333.33Farad Supercapacitor Bank Block Diagram



C1=C2=C3=C4=C5=C6=C7=C8=C9=C10=C11=C12=C13=C14=C15=C16=C17=C18=C19=C20=C21=C22=C23=C24 = 2.7V, 500F

Figure 1(b). Circuit Diagram of 14.4V and 333.33F Supercapacitor Bank Used In Experiment

B. Supercapacitor and Battery Hybrid Device

The supercapacitor-bank is explained in section A. The bank is parallel to battery for creating hybrid energy storage device as shown below in figure 2. The hybrid device results analyzation is discussed in next sections.

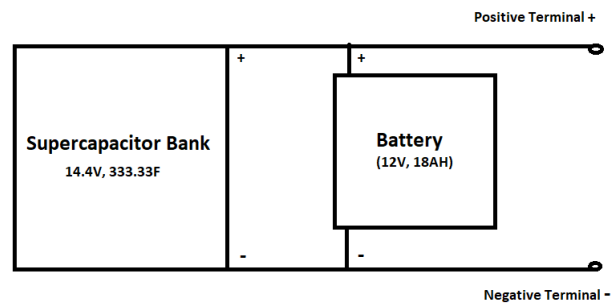

Figure 2. Supercapacitor and Battery Hybrid Device

C. Supercapacitor and Battery Hybrid Device When Charging Source is Connected

The following block diagram shows above created hybrid energy storage device. Now it is connected to charging source for analyzing it. The connected Voltage meter (Voltmeter), and Ampere meters (I-Cap and I-Bat) are connected to see its parameters while charging the device, as it is shown in Figure 3 below.

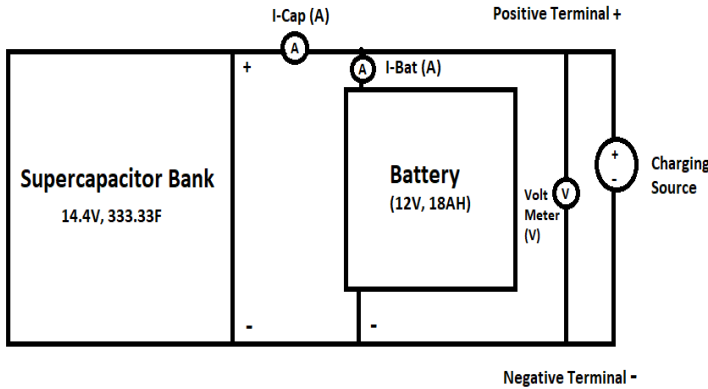

Figure 3. Supercapacitor and Battery hybrid device while charging

D. The Hybrid Device Connected to Source for Charging

The information gathered from the hybrid supercapacitor and battery device while connected to the charging source shown in Figure 3, encompassing factors such as supercapacitor bank current (I-cap), battery current (I-bat), and total voltage (V-total) of both parallel components, are compiled in Table 1.

TABLE 1: The supercapacitor bank and battery hybrid connected to a charging source, the collected parameters value.

I-Cap (A)	I-Bat (A)	V-total (V)	Time (Minutes)
1.39	0.49	12.8	1:00:30
2.27	1.18	13	1:01:00
1.86	1.22	13.2	1:01:30
1.24	1.23	13.6	1:02:00
0.89	1.23	13.9	1:03:00
0.65	1.24	14.1	1:04:00
0.48	1.25	14.2	1:05:00
0.38	1.25	14.2	1:06:00
0.3	1.25	14.3	1:07:00
0.26	1.25	14.3	1:08:00
0.23	1.23	14.3	1:09:00

E. The Hybrid Device is Connected to Charging

It can be seen in Figure 4 that initially the supercapacitor bank is consuming more current and battery is taking less current comparatively but along with time (from left to right in the figure) battery begin to take more current and supercapacitor bank consumes less current due to the charging saturation of supercapacitor bank. It reflects that the supercapacitor and battery hybrid device can absorb inrush current due to supercapacitor bank high power density.

The inrush current absorption depends on the capacity of supercapacitor bank. The higher will be the supercapacitor

bank more it will absorb the inrush current. The capacity of supercapacitor bank design depends on type of application.

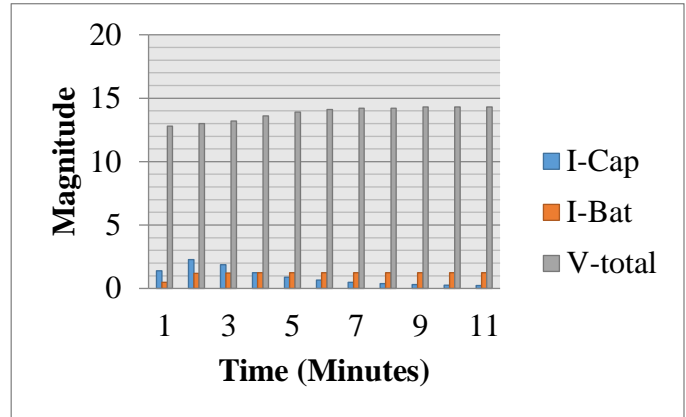

Figure 4. Characteristics of supercapacitor bank and battery hybrid device when connected to a charging source

III. APPLICATIONS

The performance of this device is excellent in electric vehicles as it enhances the vehicle’s battery life by absorbing inrush current while charging.

The hybrid device is highly beneficial for efficient power storage and supply in renewable power systems, because it absorbs inrush current while charging and enhances battery life.

Additionally, the hybrid device excels in handling fluctuating loads, showcasing a highly effective response in such situations, it absorbs power fluctuations hence prevents load from unwanted fluctuations travelling to load.

IV. CONCLUSION

In conclusion, the experiment successfully produced a supercapacitor bank designed to complement the existing battery. Combining these components resulted in the creation of a hybrid energy storage device, which was then subjected to analysis while charging. Notably, the hybrid device exhibited the ability to absorb inrush current, attributed to the high power density of the supercapacitor bank, while the battery displayed high absorption capabilities due to its own high energy density.

It is worth emphasizing that the hybrid device was designed within budget constraints during the experiment. However, it is crucial to recognize that the optimal design of this device is contingent upon the specific application requirements and the type of battery utilized. This underscores the importance of tailoring the design to meet the unique demands of different applications and battery technologies.

REFERENCES

[1] Zuo, Wenhua, Ruizhi Li, Cheng Zhou, Yuanyuan Li, Jianlong Xia, and Jinping Liu. "Battery-supercapacitor hybrid

devices: recent progress and future prospects." *Advanced science* 4, no. 7 (2017): 1600539.

[2] Cericola, Dario, Patrick W. Ruch, Rüdiger Kötz, Petr Novák, and Alexander Wokaun. "Simulation of a supercapacitor/Li-ion battery hybrid for pulsed applications." *Journal of Power Sources* 195, no. 9 (2010): 2731-2736.

[3] Glavin, M. E., Paul KW Chan, S. Armstrong, and W. G. Hurley. "A stand-alone photovoltaic supercapacitor battery hybrid energy storage system." In *2008 13th International power electronics and motion control conference*, pp. 1688-1695. IEEE, 2008.

[4] Diaz-González, Francisco, Cristian Chillón-Antón, Marc Llonch-Masachs, Samuel Galceran-Arellano, Joan Rull-Duran, Joan Bergas-Jané, and Eduard Bullich-Massagué. "A hybrid energy storage solution based on supercapacitors and batteries for the grid integration of utility scale photovoltaic plants." *Journal of Energy Storage* 51 (2022): 104446.

[5] Qi, Jiyan, and Ming Su. "Analysis of Micro-Electric Vehicle with Super Capacitor/Battery Hybrid Energy Storage System." In *Journal of Physics: Conference Series*, vol. 2459, no. 1, p. 012091. IOP Publishing, 2023.